

CODEC / AUDIO

SHEET 2

INTERFACES

TRANSMITTER

RECEIVER

SYNTH

PSU

MCM1
XMAP10

- 1=SYSTEM
- 2=CODEC
- 3=TX
- 4=RX
- 5=SYNTH
- 6=PSU
- 7=INTERFACES

© TAIT ELECTRONICS		A1
TM8000 1.36-174MHz SYSTEM		
IPN: 220-01700-06	ISSUE: 06B	VARIANT NUMBER: ?
FILE DATE: Thu May 20 09:42:45 2004		
ENGINEER: TM8000	FILE NAME: 220_01700	SHEET NUMBER: 1 OF 7

06B	UPDATED VALUES + TX REF DES TO MATCH UHF	CRAIG M			20/05/04
06A	MIGRATED FROM UNICAD	RUA S			15/12/03
05A	DCO 700051-53	CRAIG M			19/08/03
REV/ISS	AMENDMENTS	DRAWN	CHKD	D.O.	APVD

- TOPBAD BADMARK
- BOTBAD BADMARK
- TOPFID1 FIDUCIAL
- TOPFID2 FIDUCIAL
- BOTFID1 FIDUCIAL
- BOTFID2 FIDUCIAL

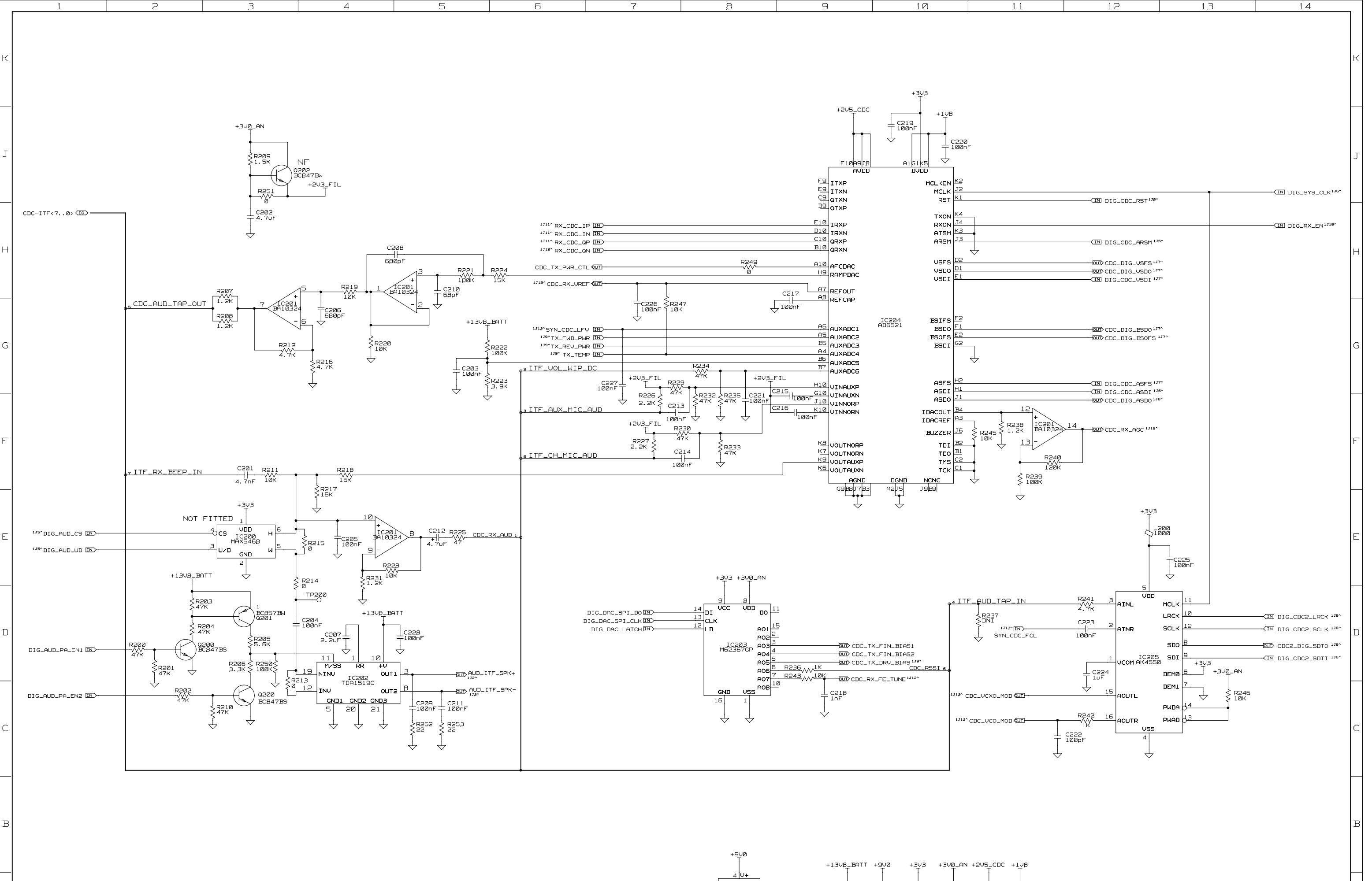

06A	MIGRATION FROM UNICAD	RUA S			15/12/03
05A	DCO 700051-53	CRAIG M			19/8/03
REV/ISS	AMENDMENTS	DRAWN	CHKD	D. O.	APVD
1					
2					
3					
4					
5					

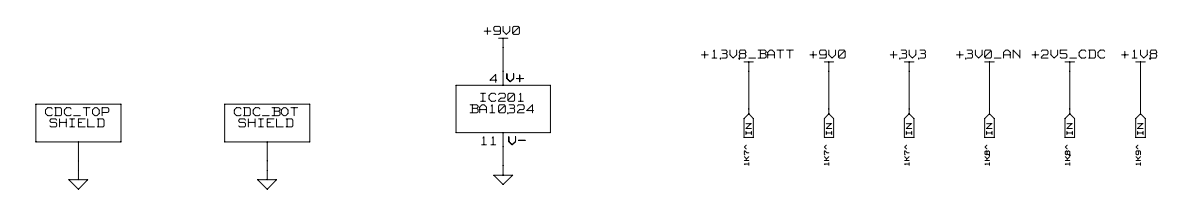

© TAIT ELECTRONICS		A1
TM8000 136-174MHZ CODEC		
IPN:	ISSUE:	VARIANT NUMBER:
220-01700-06	06B	?
FILE DATE: Thu May 20 09:42:46 2004		
ENGINEER:	FILE NAME:	SHEET NUMBER:
TM8000	220_01700	2 OF 7

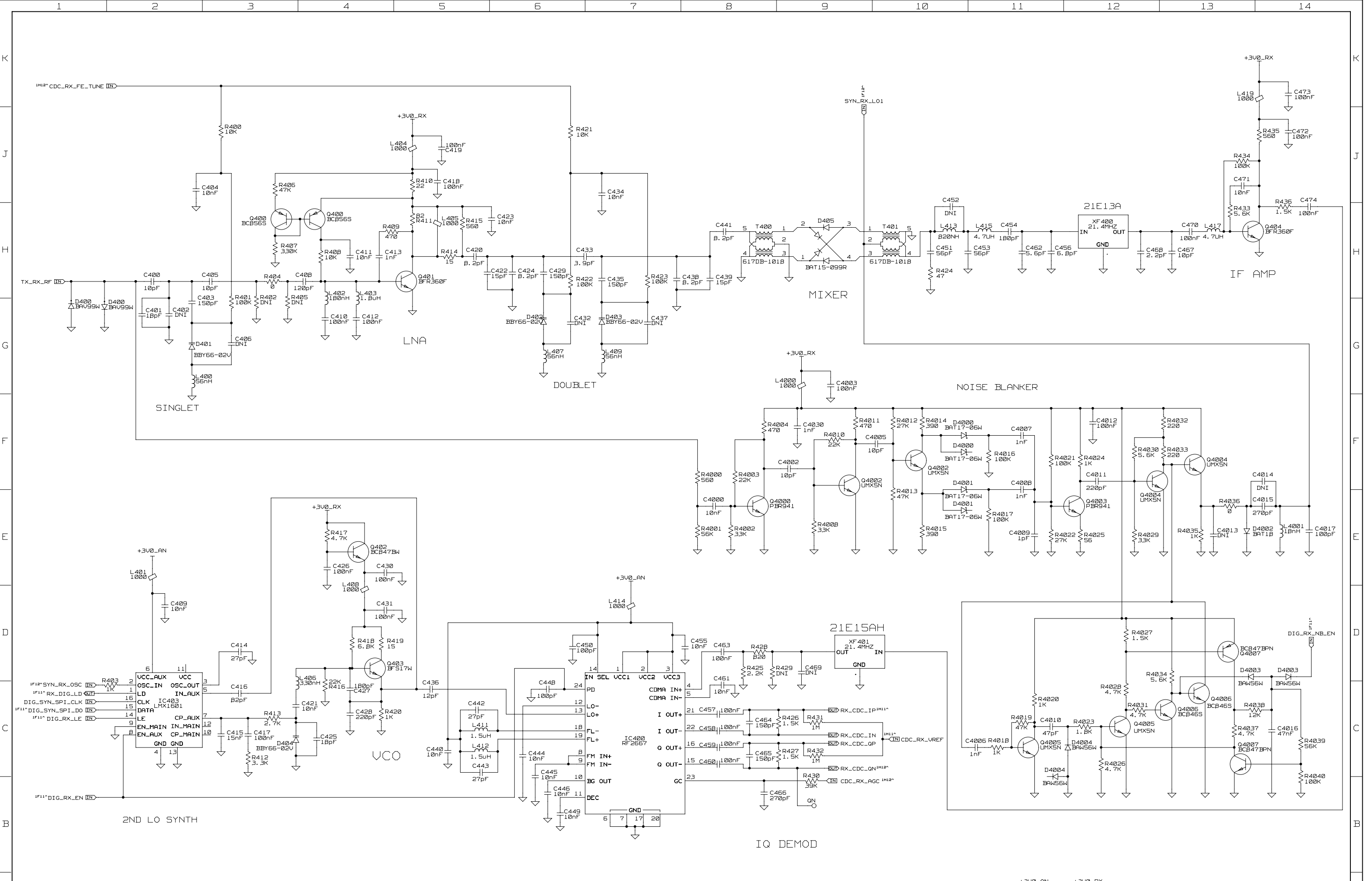

06A	MIGRATION FROM UNICAD	RUA S			15/12/03
05A	DCO 700051-53	CRAIG M			19/8/03
REV/ISS	AMENDMENTS	DRAWN	CHKD	D. O.	APVD
1					
2					
3					
4					
5					

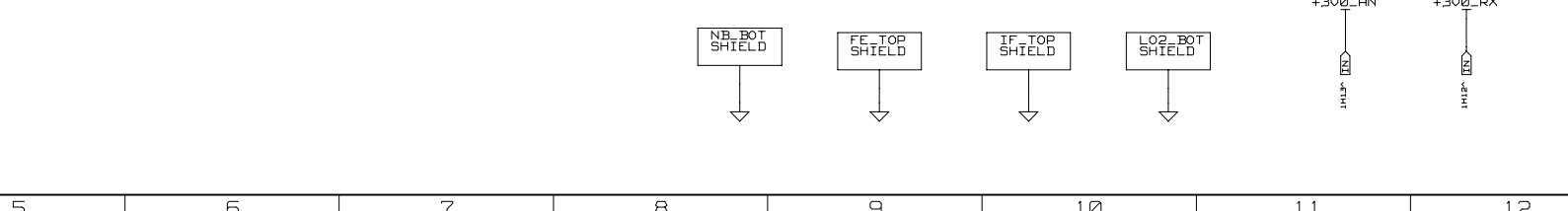

© TAIT ELECTRONICS		A1
TM8000 136-174MHZ RECEIVER		
IPN: 220-01700-06	ISSUE: 06B	VARIANT NUMBER: ?
FILE DATE: Thu May 20 11:38:08 2004		
ENGINEER: TM8000	FILE NAME: 220_01700	SHEET NUMBER: 3 OF 7

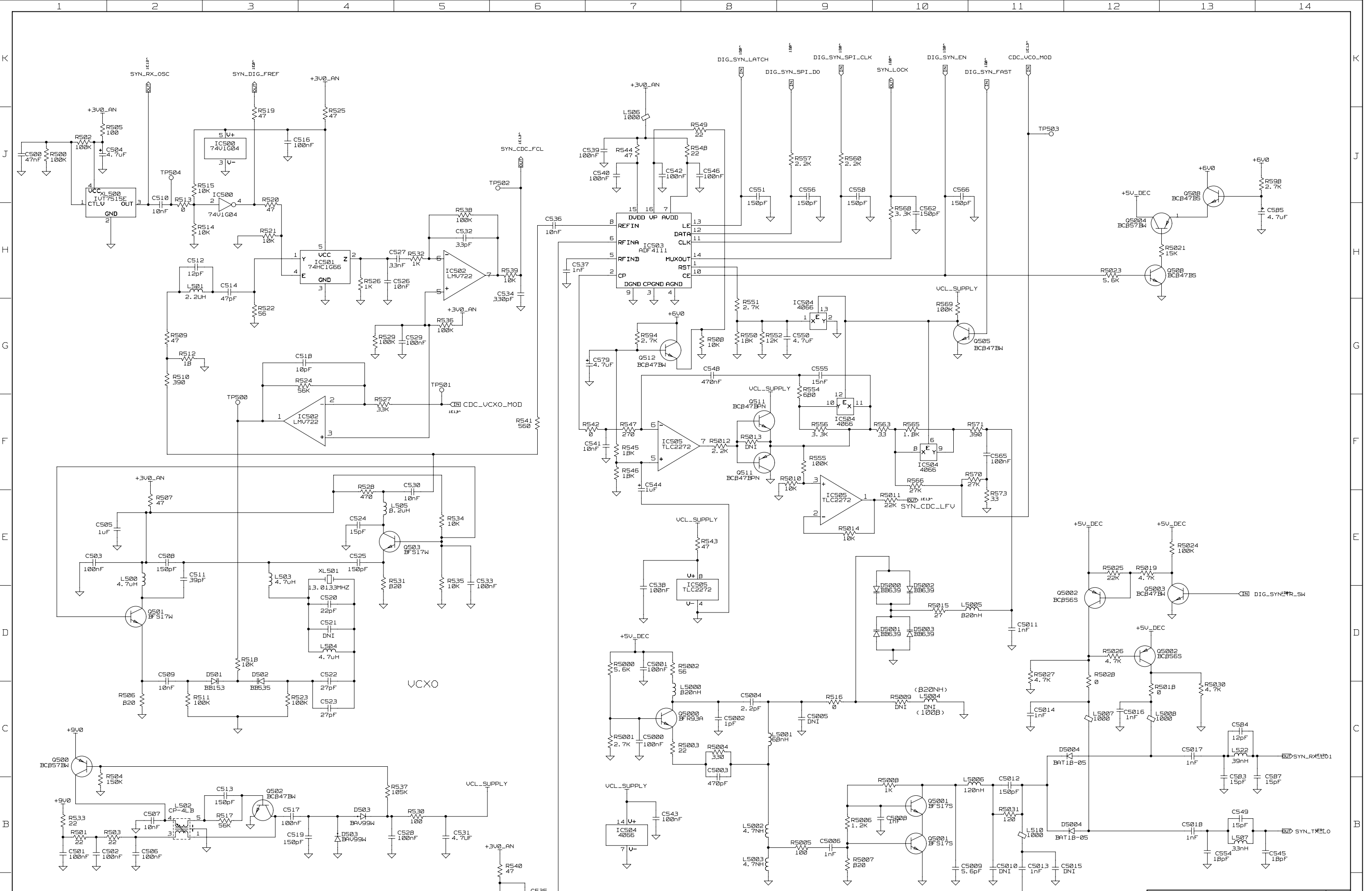

06B	CHANGED TX DESIGNATION TO MATCH UHF AND 216MHZ	CRAIG M	?	?	?	18/05/04
06A	MIGRATION FROM UNICAD	RUA S				12/12/03
05A	DCO 700051-53	CRAIG M				19/2/03
REV/ISS	AMENDMENTS	DRAWN	CHKD	D. O.	APVD	DATE

© TAIT ELECTRONICS | A1

TM8000 136-174MHZ
SYNTH & UCOS

IPN: 220-01700-06 | ISSUE: 06B | VARIANT NUMBER: ?

FILE DATE: Thu May 20 12:09:47 2004

ENGINEER: TM8000 | FILE NAME: 220_01700 | SHEET NUMBER: 4 OF 7

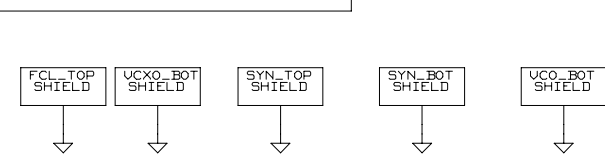

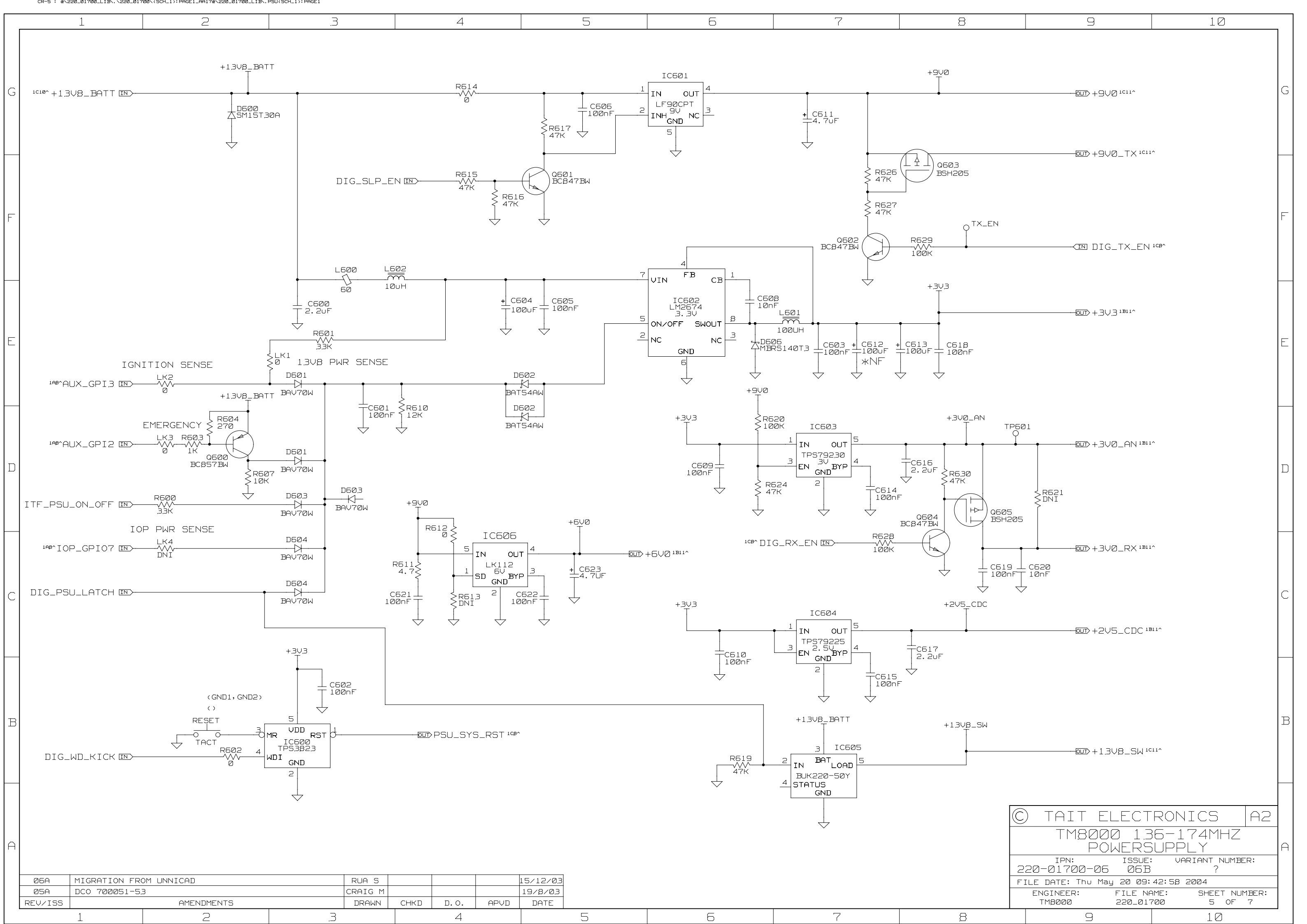

© TAIT ELECTRONICS		A2
TM8000 1.36-174MHZ POWERSUPPLY		
IPN: 220-01700-06	ISSUE: 06B	VARIANT NUMBER: ?
FILE DATE: Thu May 20 09:42:58 2004		
ENGINEER: TM8000	FILE NAME: 220-01700	SHEET NUMBER: 5 OF 7

06A	MIGRATION FROM UNNICAD	RUA S			15/12/03
05A	DCO 700051-53	CRAIG M			19/8/03
REV/ISS	AMENDMENTS	DRAWN	CHKD	D. O.	APVD DATE

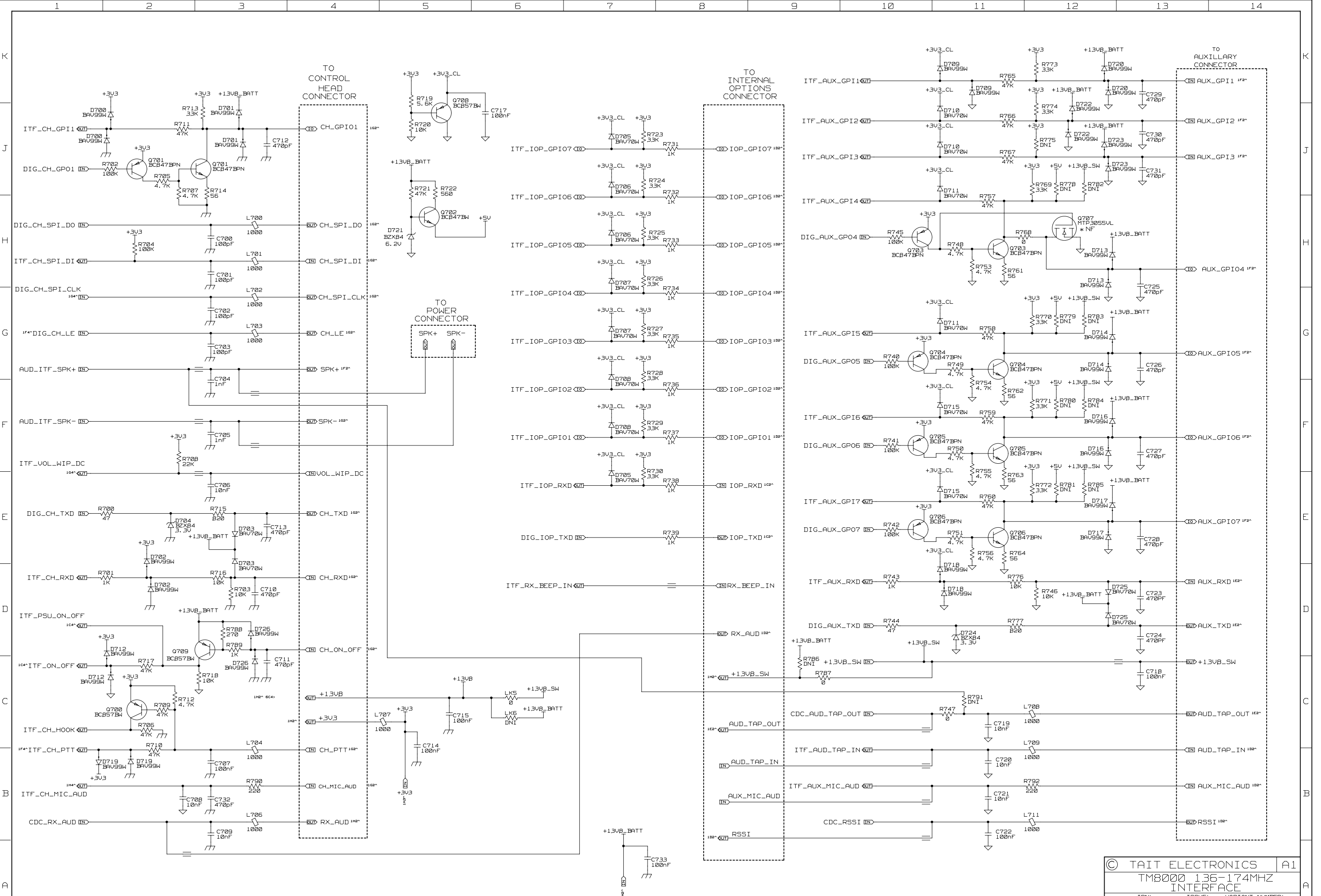

06A	MIGRATION	RUA S			15/12/03
05A	DCO 700051-53	CRAIG M			19/8/03
REV/ISS	AMENDMENTS	DRAWN	CHKD	D. O.	APVD

© TAIT ELECTRONICS		A1
T8000 136-174MHz INTERFACE		
IPN: 220-01700-06	ISSUE: 06B	VARIANT NUMBER: ?
FILE DATE: Thu May 20 09:43:01 2004		
ENGINEER: TMB000	FILE NAME: 220_01700	SHEET NUMBER: 6 OF 7

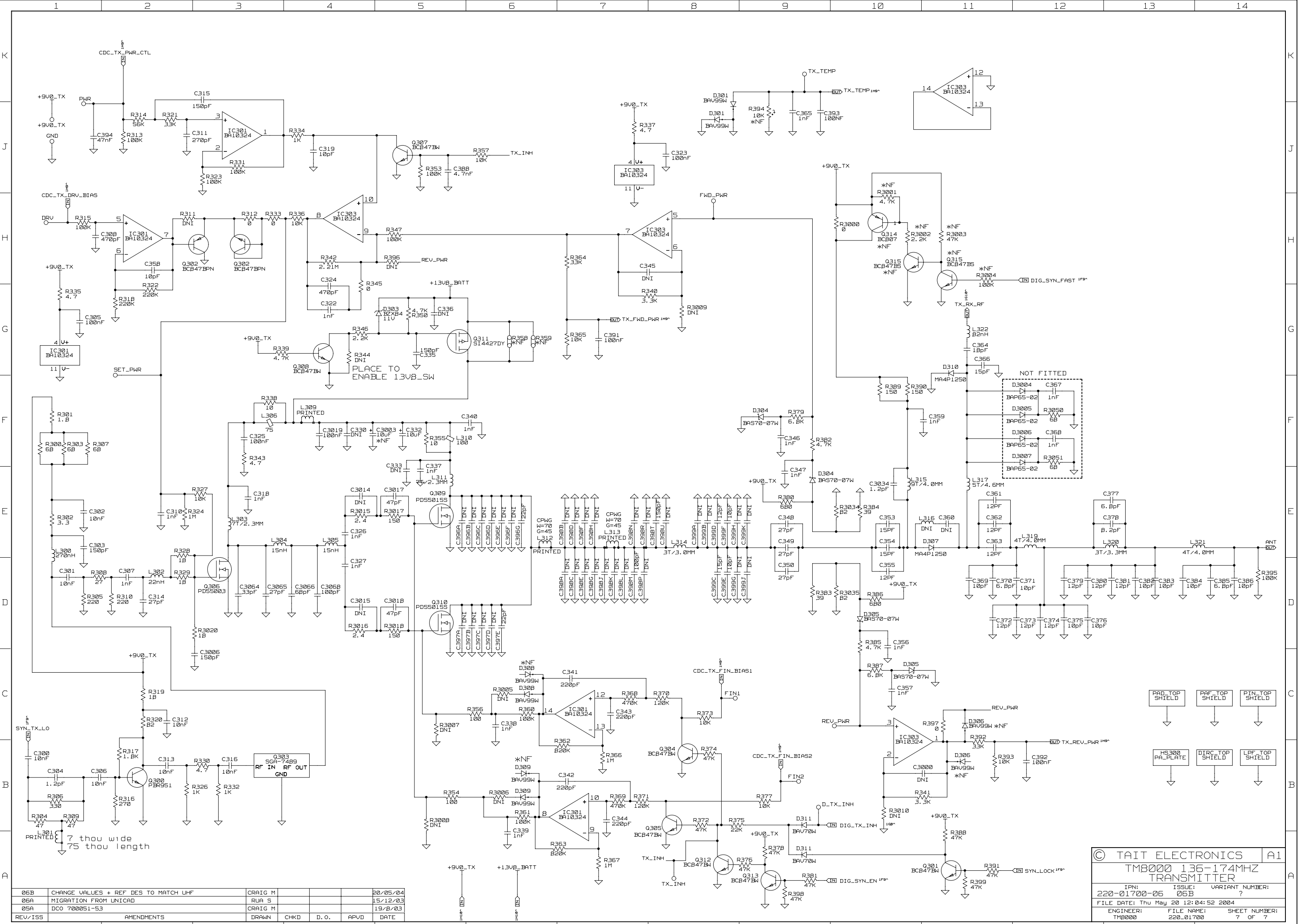

06B	CHANGE VALUES + REF DES TO MATCH UHF	CRAIG M			20/05/04
06A	MIGRATION FROM UNICAD	RUA S			15/12/03
05A	DCO 700051-53	CRAIG M			19/8/03
REV/ISS	AMENDMENTS	DRAWN	CHKD	D.O.	APVD

© TAIT ELECTRONICS | A1
 TM8000 1.36-174MHZ
 TRANSMITTER
 IPN: 220-01700-06 | ISSUE: 06B | VARIANT NUMBER: ?
 FILE DATE: Thu May 20 12:04:52 2004
 ENGINEER: TM8000 | FILE NAME: 220_01700 | SHEET NUMBER: 7 OF 7

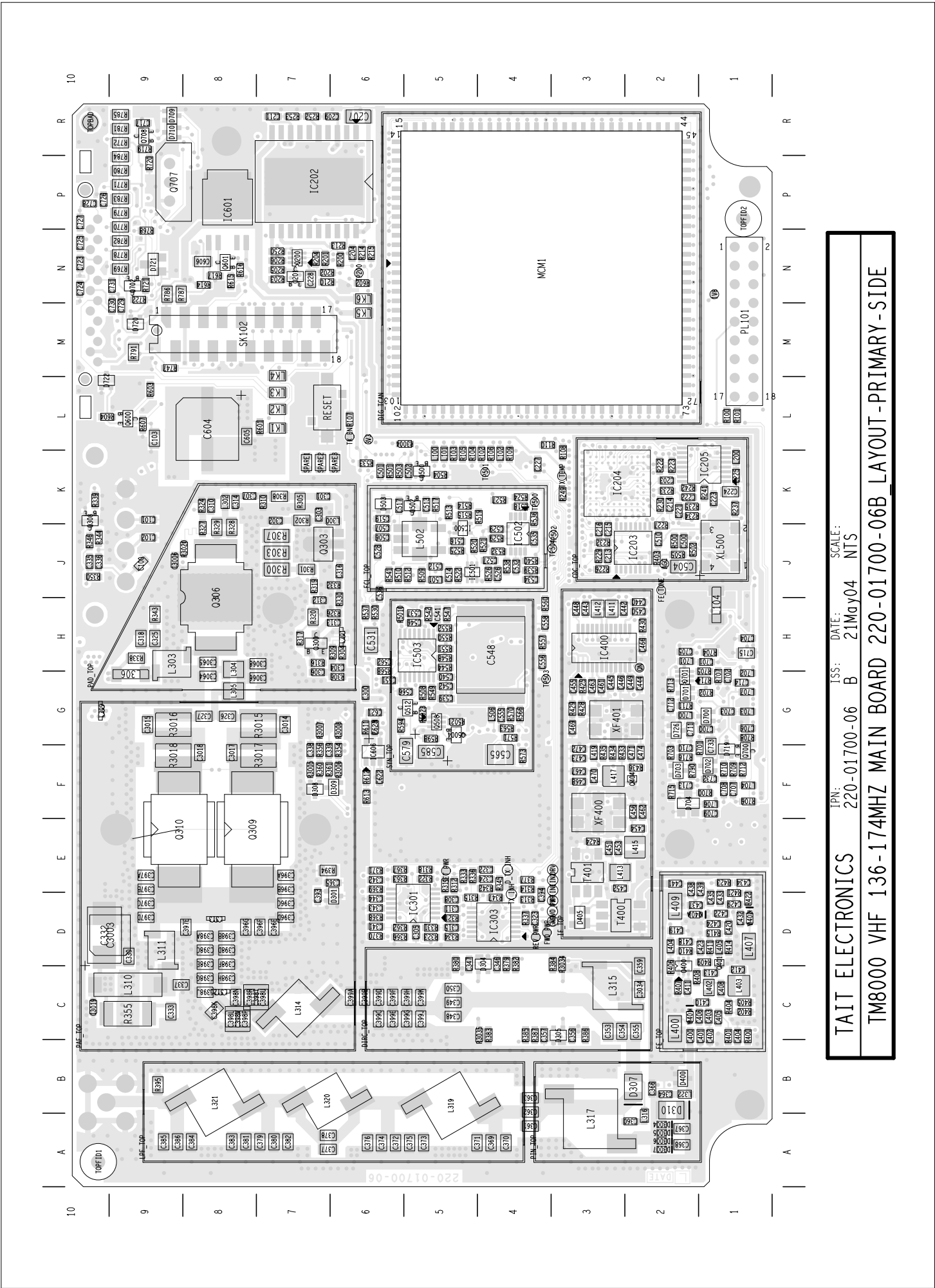

TAIT ELECTRONICS IPN: 220-01700-06 B DATE: 21May04 SCALE: NTS
 TM8000 VHF 136-174MHZ MAIN BOARD 220-01700-06B LAYOUT-PRIMARY-SIDE

